

# APSC 1001 & CS 1010

---

## Deep dive into Raspberry Pi with Python

Prof. Kartik Bulusu, MAE Dept.

Detecting Heart Beats

**Teaching Assistants:**

Sara Tenaglio, BME Dept.

Catherine Karpova, BME Dept.

Zachary Stecher, CEE Dept.

**Learning Assistants:**

Jonathan Terry, CS Dept.

Ethan Frink, MAE Dept.

Jack Umina, CS Dept.

Olivia Legault, CS Dept.

Alexis Renderos, MAE Dept.



School of Engineering  
& Applied Science

THE GEORGE WASHINGTON UNIVERSITY

Fall 2021

Photo: Kartik Bulusu

# Photoplethysmogram or Pulse sensor – Explained

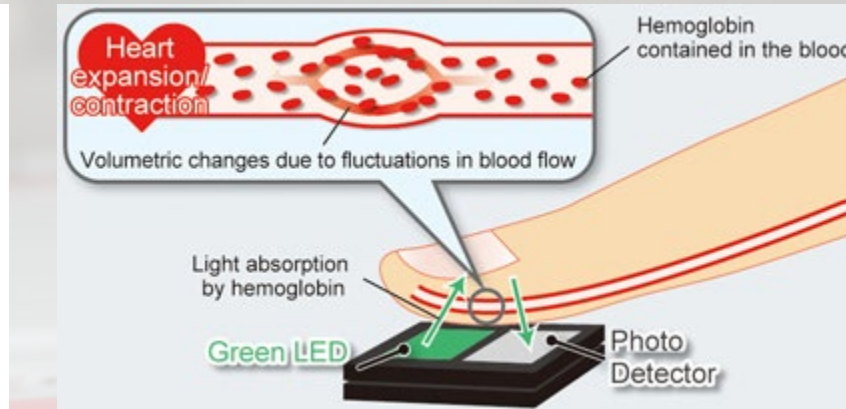

**Green light source which has a high absorption rate in hemoglobin and less susceptibility to ambient light**

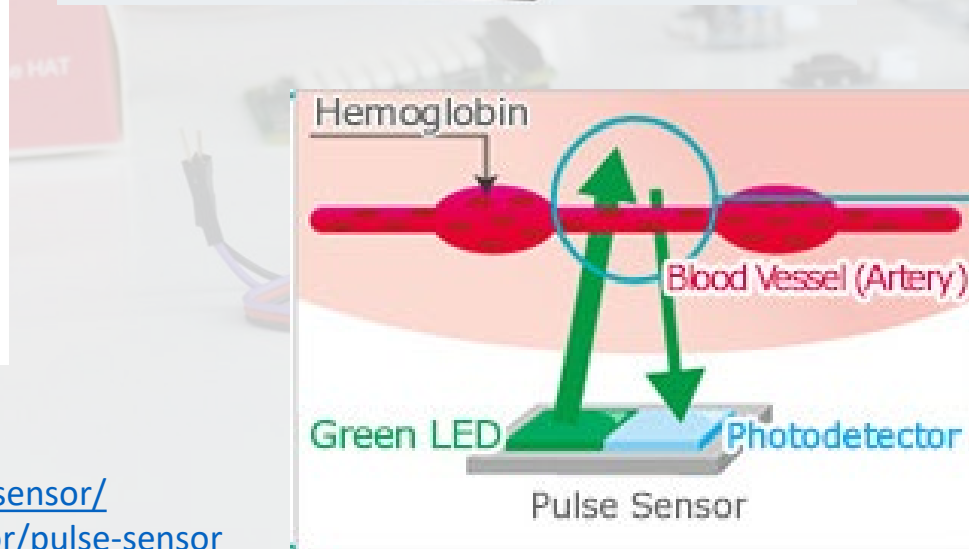

The amount of light absorbed will vary based on changes in blood vessel volume, resulting in a waveform as shown below.



**Sources:**

- <https://pulsesensor.com/>
- <https://www.electroschematics.com/heart-rate-sensor/>
- <https://www.rohm.com/electronics-basics/sensor/pulse-sensor>
- <https://www.rohm.com/sensor-shield-support/heart-rate-sensor>

# Frequency of signals and measurements

**Frequency** is the number of occurrences of a repeating event per unit **time**.

●  $f = 0.5 \text{ Hz}$   
 $T = 2.0 \text{ s}$

●  $f = 1.0 \text{ Hz}$   
 $T = 1.0 \text{ s}$

●  $f = 2.0 \text{ Hz}$   
 $T = 0.5 \text{ s}$

Wikimedia Commons

The **sampling frequency** or **sampling rate,  $f_s$** , is the average number of samples obtained in one second (*samples per second*), thus  **$f_s = 1/T$** .

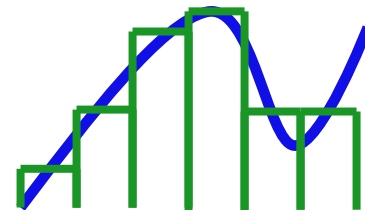
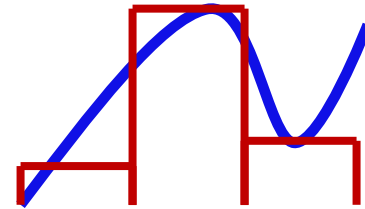
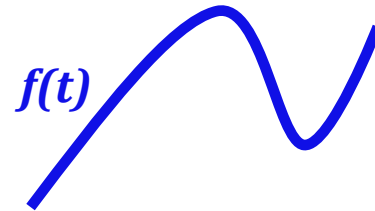

The general range of hearing for young people is **20 Hz to 20000 Hz**.

Audio CD, most commonly used with MPEG-1 audio is sampled at **44100 Hz**

HD DVD (High-Definition DVD) audio tracks are sampled at **98000 Hz**

*The approximately double-rate requirement is a consequence of the **Nyquist theorem**.*

# Introducing the PCF8591 8-bit A/D and D/A converter

Potentiometer – to adjust the quality of the analog input signal by changing the “gain”.

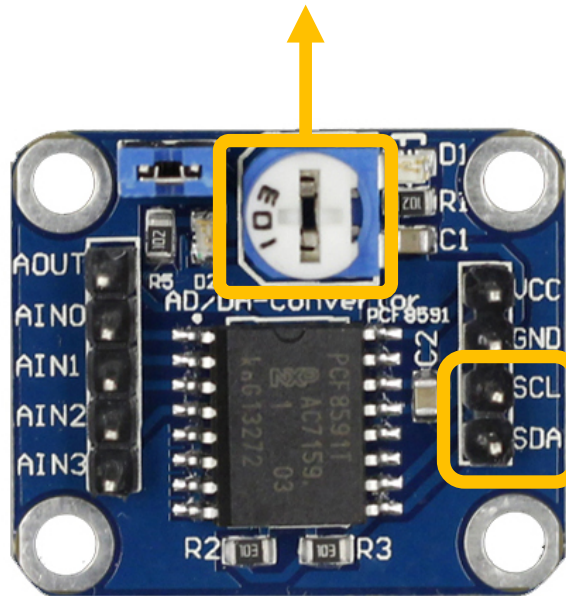

SYMBOL	PIN	DESCRIPTION
AINO	1	analog inputs (A/D converter)
AIN1	2	
AIN2	3	
AIN3	4	
A0	5	hardware address
A1	6	
A2	7	
V <sub>SS</sub>	8	negative supply voltage
SDA	9	I <sup>2</sup> C-bus data input/output
SCL	10	I <sup>2</sup> C-bus clock input
OSC	11	oscillator input/output
EXT	12	external/internal switch for oscillator input
AGND	13	analog ground
V <sub>REF</sub>	14	voltage reference input
AOUT	15	analog output (D/A converter)
V <sub>DD</sub>	16	positive supply voltage

I<sup>2</sup>C (Inter-Integrated Circuit, [eye-squared-C](#)), alternatively known as I<sup>2</sup>C or IIC, is a [synchronous](#), [multi-master](#), [multi-slave](#), [packet switched](#), [single-ended](#), [serial communication bus](#) invented in 1982 by [Philips Semiconductors](#).

It is widely used for attaching lower-speed peripheral [ICs](#) to processors and [microcontrollers](#) in short-distance, intra-board communication.

Sources:

<https://en.wikipedia.org/wiki/I%C2%B2C>

[http://wiki.sunfounder.cc/index.php?title=PCF8591\\_8-bit\\_A/D\\_and\\_D/A\\_converter\\_Module](http://wiki.sunfounder.cc/index.php?title=PCF8591_8-bit_A/D_and_D/A_converter_Module)

# Pulse sensor + A/D converter

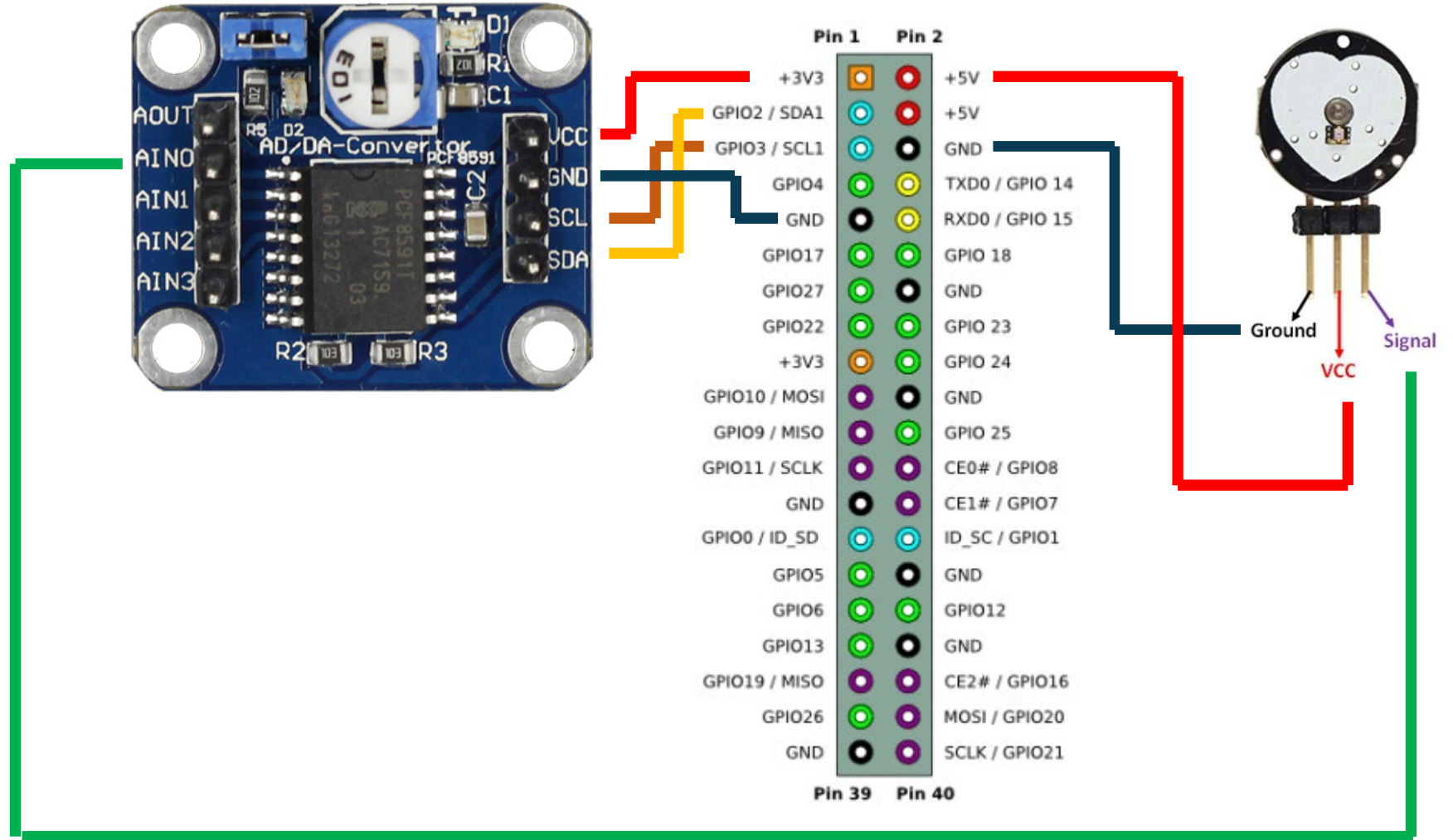

Sources:

- <https://how2electronics.com/pulse-rate-bpm-monitor-arduino-pulse-sensor/>
- <https://medium.com/@sarala.saraswati/connecting-to-your-raspberry-pi-console-via-the-serial-cable-44d7df95f03e>
- <http://wiki.sunfounder.cc/index.php?title=PCF8591> 8-bit A/D and D/A converter Module

# Goal of the lab segment

## Co-work

- Observe, ask and try in groups

## Make

- Build-a-hack
- Pulse sensors, A/D converter and Raspberry Pi 3B+

## Analyze data using Python

## Record

- Challenges, Opportunities, Gaps and Surprises

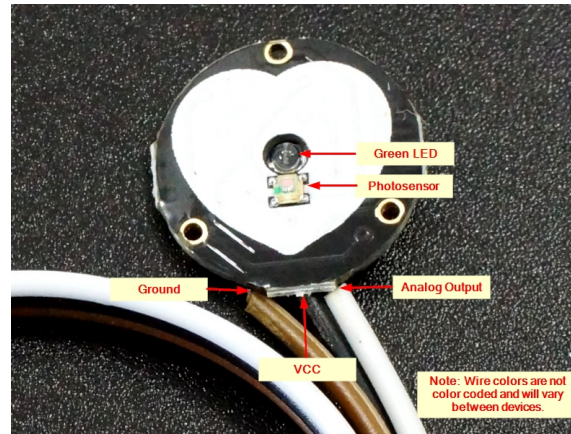

## Record your pulse at your wrist

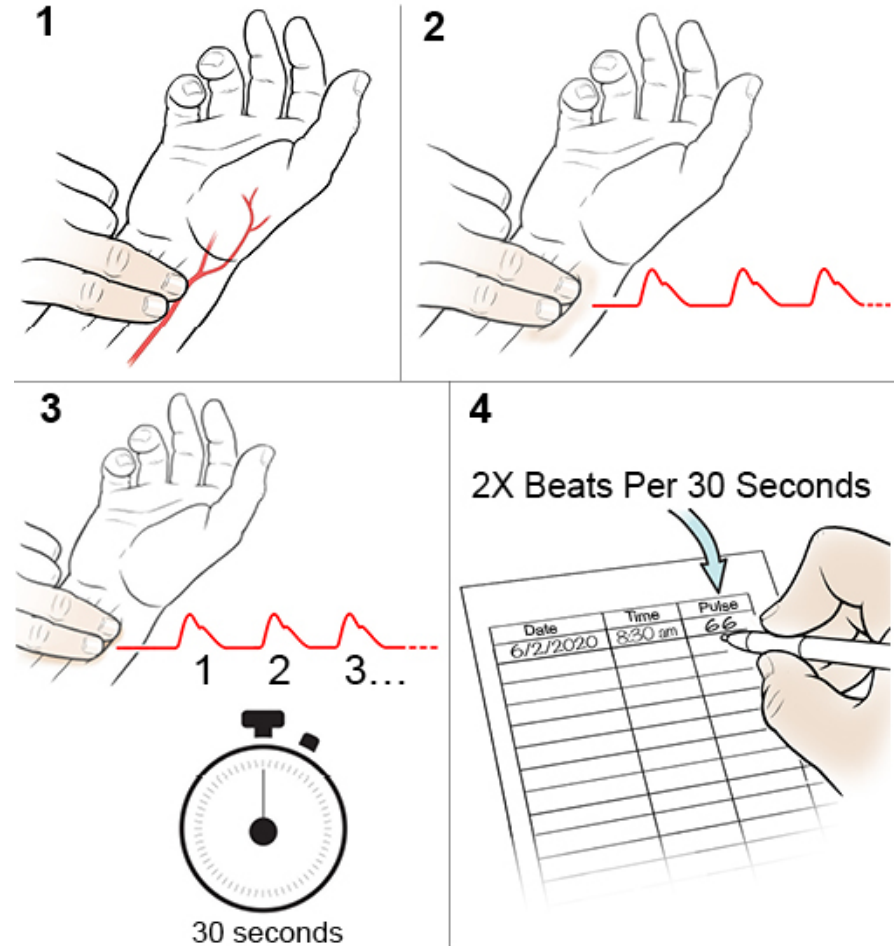

Sources:

<https://www.spectrumhealthlakeland.org/lakeland-ear-nose-and-throat/ent-health-library/Content/3/90852/>  
<https://protosupplies.com/product/pulsesensor-heart-rate-sensor-module/>

**Recorded pulse signal**

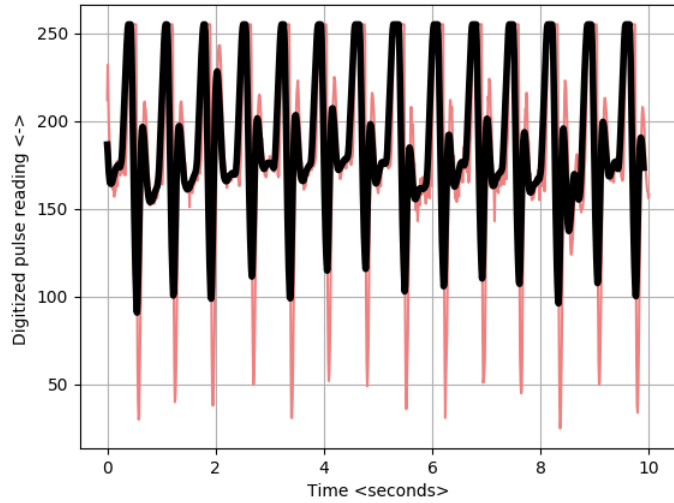

**Pulse signal peaks detected by the Raspberry Pi 3B+ system**

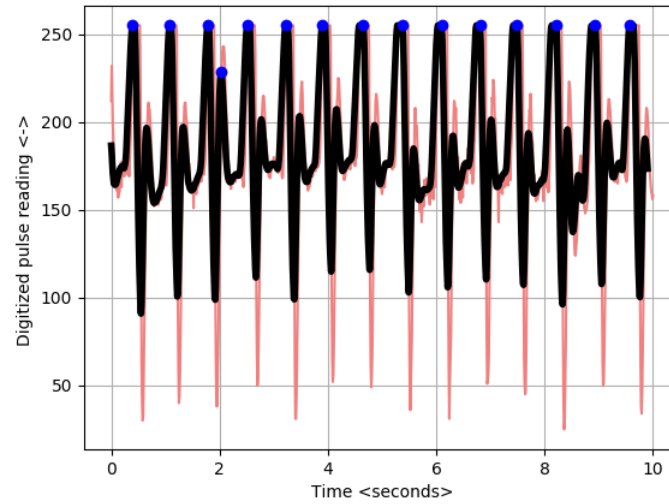

Signals generated by the heart rate measurements system after adjusting the potentiometer settings

**Pulse signal with high gain setting**

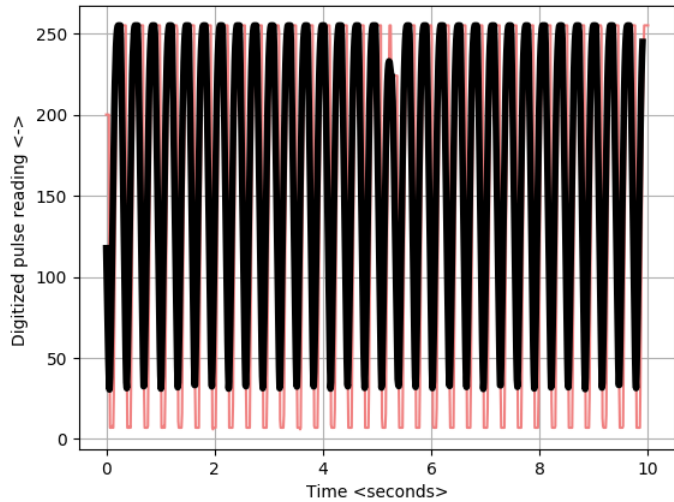

**Pulse signal with low gain setting**

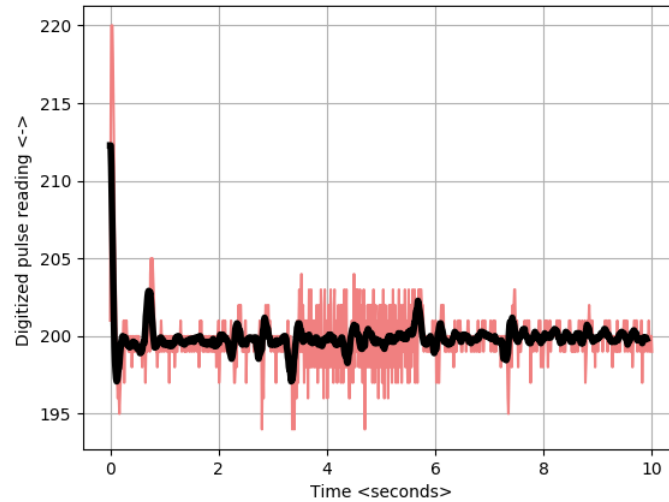

**Typical pulse signal with optimal gain setting**

